



MODEL 2880-OWI

Oil/Water Interface Transmitter

User Manual

Technical Support
Continental North America Toll Free 1-(800) 387-9487
Ph: +1 (905) 829-2418 Fx: +1 (905) 829-4701



A Product of Arjay Engineering Ltd.
Oakville, Ontario, Canada

www.ArjayEng.com

2880-OWI / 2881-OWI / 2882-OWI Oil/Water Interface Transmitter



Reliable monitoring of oil/water interface and emulsions

Over 40 years of capacitance experience stands behind the 2880-OWI transmitter. The sensing probe continuously monitors the capacitance of the inserted probe. As the interface or emulsion layer (rag layer) crosses over the probe, a proportional 4-20 mA output is provided. Typical applications include oil water separators, oil/water knock-out tanks, treater trains and decanting tanks.

- capacitance technology does not foul or require cleaning
- no moving parts
- remote monitor mounts safely away from the process

The 2880-OWI sensing probe monitors the capacitance field around the probe. A calibration is performed against the an oil condition and a water condition. The active portion of the probe is fully submerged into the liquid and sized to your targeted range of interest. As the oil/water interface or emulsion crosses or envelopes the probe, the capacitance change is tracked and an output of 4-20 mA is provided.



explosion proof probe head

3/4" npt 316SS process connection on standard probes (flanges optional)

Inactive probe Sheath (length to order)

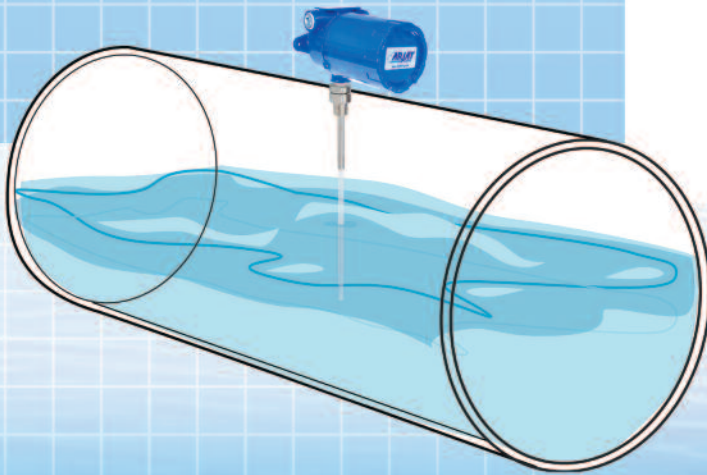

Teflon coated probe (length to order)

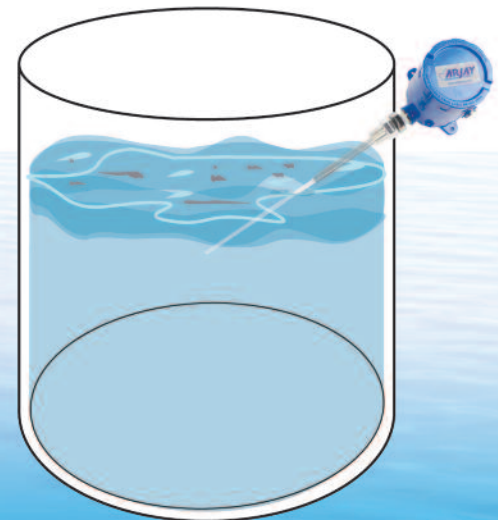

2880-OWI

Features and Benefits

- no moving parts
- electronics is integral to the probe
- high corrosion resistant Teflon and stainless steel wetted parts
- capacitance technology responds to all oil types
- HF capacitance technology does not require routine cleaning
- easy calibration and control set-up

Technical Specifications - Electronics

Operating Temp.	-20°C to +55°C
Resolution	.007% (.07 pF at 1,000 pF)
Accuracy	.04% of full scale pF
Power Input	12 vdc or 24 vdc, 0.1 amp max. 100-240 vac +/- 10%
Communication	RS-485 Modbus

Control Interface

2880-OWI	0/4-20 mA non-isolated output
2881-OWI	0/4-20 mA isolated output
2882-OWI	0/4-20 mA non-isolated output and 2 x 10amp@240 vac, SPDT, dry relays

Optional Viewing window of % Level LCD

Technical Specifications - Probe

Process Temp.	-60°C to +260°C (Teflon probe)
Pressure	103 bar/10342 kPa/1500psi at stable temperature
CRN	ABSA-CRN #OF07450.2
Wetted Parts	316SS and Teflon

Probe materials are eligible for NACE MR-0175 Compliance

Hazardous Location Use

Available Component Certifications may be suitable to your application. Consult Arjay for assistance.

2880 Electrical Safety Housing	UL, CSA, or IEC 61010 UL / FM / CSA Class 1, Group B,C,D; Class II, Group E,F,G
Probe	CSA Class 1, Group C,D

The electronics for this model can also be mounted remote from the probe. Refer to the Model 2852-OWI. The probe becomes Intrinsically Safe when ordered with an IS Barrier installed in 2852-OWI control panel: CSA Div 1, Class 1, Groups A,B,C,D

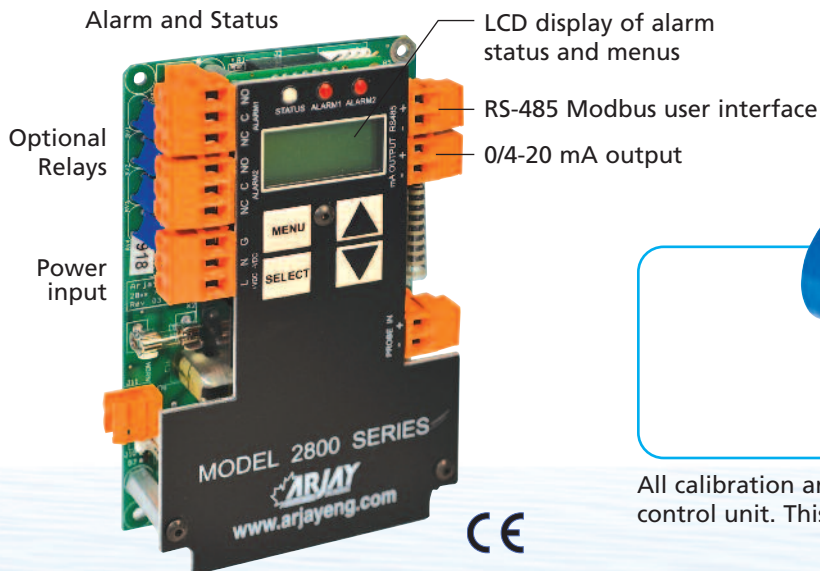

All calibration and power wiring is done at the main control unit. This is mounted directly onto the probe.



Arjay Engineering Ltd. 2851 Brighton Road Oakville, Ontario Canada L6H 6C9

<http://www.arjayeng.com> telephone: ++1 905-829-2418 N. America toll free: 1-800-387-9487 fax: ++1 905-829-4701



TABLE OF CONTENTS

1.0	INSTRUMENT OVERVIEW	3
1.1	Features	3
1.2	Model # Table	3
1.3	Specifications	3
2.0	INSTALLATION	5
2.1	Probes	5
2.2	Probe installation	5
2.3	Electrical Installation	8
2.4	Glossary of Symbols	9
3.0	STARTUP AND CALIBRATION	10
3.1	Startup	10
3.2	Menu Flow Chart	10
3.2.1	Menu Description	10
3.2.3	Data Entry	11
3.3	2880 Transmitter Calibration	11
3.3.1	Auto Calibration	11
3.3.2	Manual Calibration	12
4.0	SETUP AND NETWORK	13
4.1	2880 Transmitter Setup	13
4.2	2882 Transmitter Relay Setup (2882 Option only)	14
4.3	2880 Transmitter Network	15
4.3.1	Modbus Configuration	15
4.3.2	2800 Series Modbus Register Mapping	16
5.0	TROUBLESHOOTING	17
6.0	FLOW CHARTS	18

1.0 INSTRUMENT OVERVIEW

The 2880-OWI sensing probe monitors the capacitance field around the active probe. As the oil/water interface level moves up and down the probe, the capacitance change in picofards (pF) is monitored by the Arjay processor and translated into a 4-20 mA proportional output and Modbus RS-485 communication.

After the probe is installed and the vessel is filled with liquid, a calibration will be required by entering the % value of two different oil/water interface levels. The oil/water interface level must be physically changed in the vessel to allow the 2880-OWI to match your entered % interface level against the pF reading of the probe.

1.1 Features

- Microprocessor based capacitance level transmitter
- 4-20mA proportional output with optional signal isolator
- 4-20 mA can be:
 - Direct acting 4 to 20 mA = 0% water (100%oil) to 100% water (0% oil) or
 - Indirect acting 4 to 20 mA = 0% oil (100% water) to 100% oil (0% water)
- Modbus protocol via RS-485 for access by Arjay handheld, Central Access Panel or compatible system
- Local 2 point Auto or Manual calibration or remote calibration via network
- User specified custom features may be added by contacting Arjay Engineering Ltd.

1.2 Model # Table

MODEL	DESCRIPTION
2880-OWI	PROBE MOUNTED 4-20mA (non-isolated)
2881-OWI	PROBE MOUNTED 4-20mA (isolated)
2882-OWI	PROBE MOUNTED 4-20mA (non-isolated), two alarm relays

1.3 Specifications

Power Input:	12 VDC or 24 VDC, (specify at the time of order) 2880 and 2881: 100 mA maximum 2882: 250 mA maximum
User Interface:	
Display & Keypad	Two line LCD with % display of Level, select menu or enter values by keypad
Communication Interface:	RS-485 Modbus
Analog :	
mA Signal Output	4-20 mA DC, 900 Ohms max (24VDC), isolated (optional)**

Instrument Performance:

Measuring Range	0 - 9,999 pF (most applications are 100pF to 500pF)
Accuracy	0.2% of Level or Full Scale capacitance via network display. (0.1% of Full Scale on 4-20mA)
Resolution	0.1% of Full Scale Level on 4-20 / 0-20mA output 0.05% of Level via network display 0.002% of Full Scale capacitance via network display
Calibration	2 point Auto calibration and Manual calibration

Environmental:

Operating Temperature	-20 °C to +55 °C (Transmitter) -60 °C to 260 °C (probe)
Relative humidity	0 to 95% (non-condensing)
Installation Category	II
Pollution Degree	2

Mechanical Specification:

Enclosure Type	Class I Group B, C & D; Class II Group E, F & G; Class III enclosure Type 3 & 4
Weight	2.5 Kg (5.5lbs) max. (excluding probe) Probe length is customer specified.

2.0 INSTALLATION

NOTE: If any damage to the instrument is found, please notify an Arjay Engineering representative as soon as possible prior to installation.

2.1 Probes

The 2880-OWI Series Level Transmitter consists of the transmitter enclosure fitted with a capacitance probe. The probe length is customer specified for the tank and range of interface to be measured. Teflon coated probes are most typical. Most probes will include an inactive stainless steel sheath on the upper portion of the probe. This is to blind the probe from the affects of entrance nozzles, vapours, and changes in the upper liquid/gas phase.

The active portion of the 2880-OWI probe must only see oil, water, or the interface combination of oil and water. If the overall liquid level lowers to expose the active portion of the probe to vapour, the output will indicate a decreasing interface level (less water, more oil).

It is recommended to use a flange, union, or retraction device for easy retraction of the probe from the tank while maintaining the wiring connections. This can aide in calibration and routine testing.

2.2 Probe installation

The factory process connection is a 3/4" MNPT 316SS fitting (standard probes) or 1" MNPT (heavy duty probes). Flanges, concentric shields and retraction devices are available as options. The entrance configuration may vary depending on the application requirements.

WHEN USING THE PROBE FITTING, USE A WRENCH ON THE LOWER FITTING ONLY. The probe fittings are compression type with Teflon ferrules assembled by applying torque between the two hex sections. The fittings are sealed at the factory to provide a compression seal capable of withstanding high pressures. Once opened they cannot be reassembled without new ferrules.

The probe orientation can be vertical or angled. The length of the exposed active probe needs to extend the full vertical interface change level (refer to Drawing 2.1 and 2.2). Concentric shields can be considered for improved linearity. Shields should only be used on clean separations where clogging from a rag (emulsion) layer is not a concern. The following points are important when installing the probe:

- 1- **Reference ground:** This is important for accurate measurements and is typically the metal walls of the tank. For non-metallic tanks, a concentrically shielded probe is required in which case the shield provides its own Ground. **IMPORTANT:** For standard threaded entry and flange entry probes (without concentric shields), make sure the fittings are clean to ensure a **GOOD ELECTRICAL CONNECTION BETWEEN THE PROBE HEAD ENCLOSURE AND THE TANK (REFERENCE GND)**.
- 2- **The distance between the probe and the ground reference:** This only applies to probes without concentric shields. The closer the distance to the tank wall, the greater the sensitivity of measurement; too close and bridging problems may occur.
- 3- **The degree of parallelism between the probe and the reference ground:** A probe parallel to the reference ground will provide the best linear output signal. Note: the concentric shield option is inherently linear due to the concentric shield.
- 4- **The measurement accuracy may be affected by the temperature change of the material in the tank.** The amount of measurement error depends on the material. If the

temperature change is excessive, temperature correction may be required. Contact the Arjay representative for more information.

- 5- **Agitators or moving objects in the tank:** Moving objects in the tank close to the probe such as agitator blades, moving baffles etc. appear as moving ground references to a capacitance probe and will cause measurement errors. In applications where these objects are present, a concentrically shielded probe should be used.

CAUTION: INSTALL THE PROBE WITH CARE: THE TEFLON SHEATH IS USED TO ELECTRICALLY ISOLATE THE METAL PROBE FROM THE LIQUID. DAMAGE CAUSING LEAKS MAY CAUSE READING ERRORS.

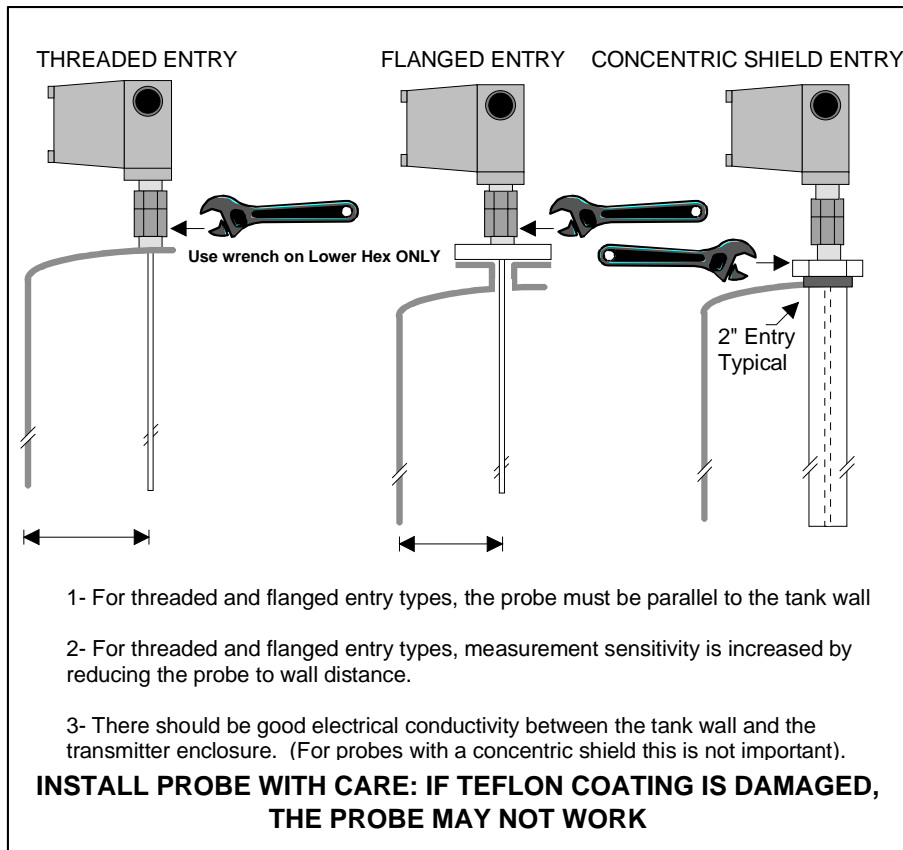

Figure 2.0

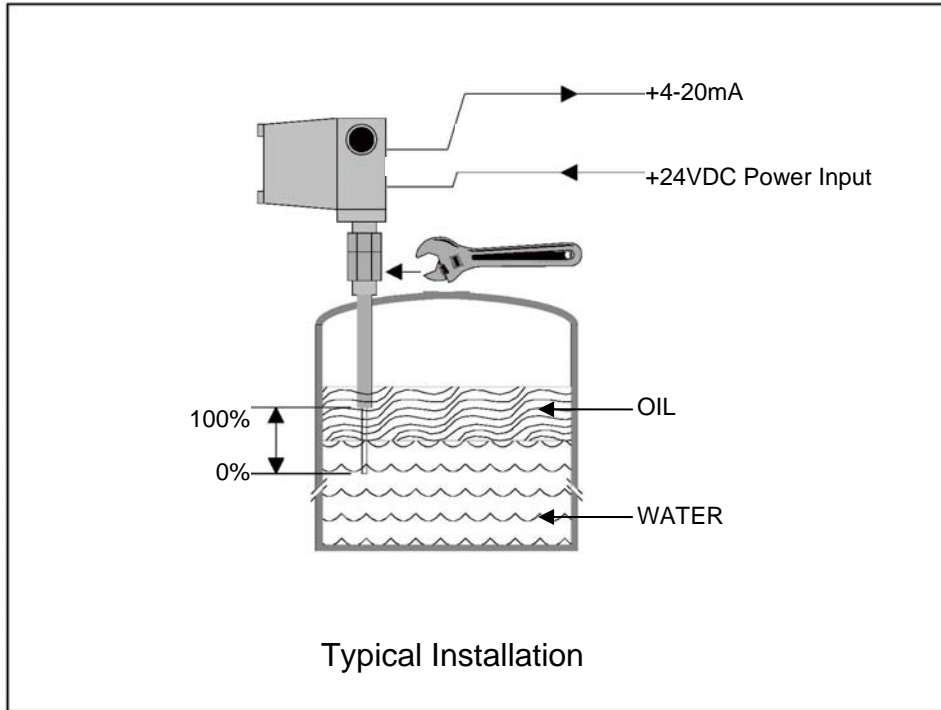

Figure 2.1

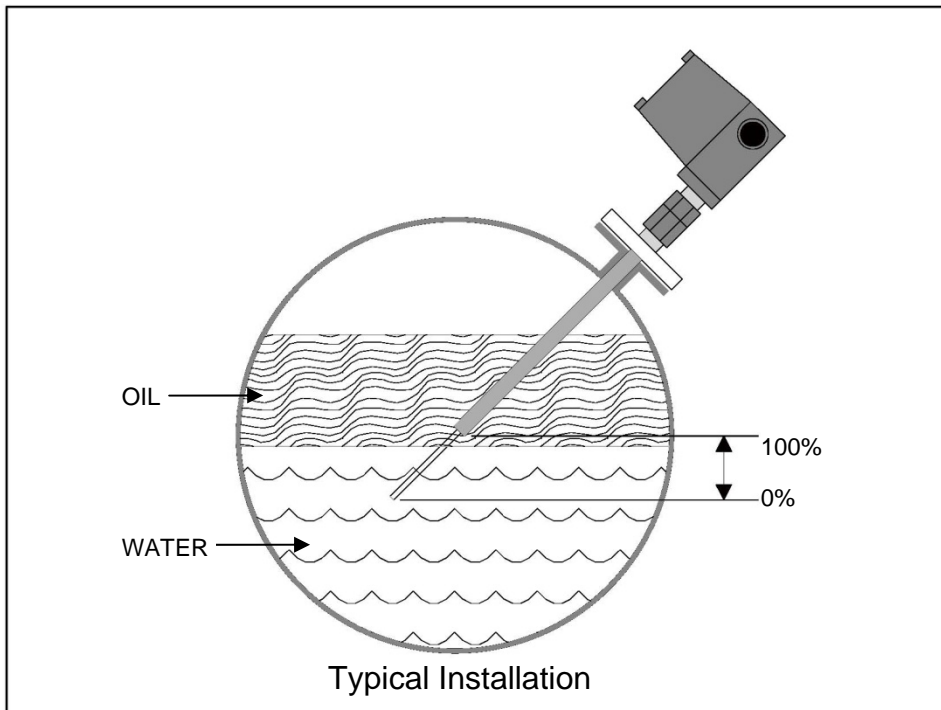

Figure 2.2

2.3 Electrical Installation

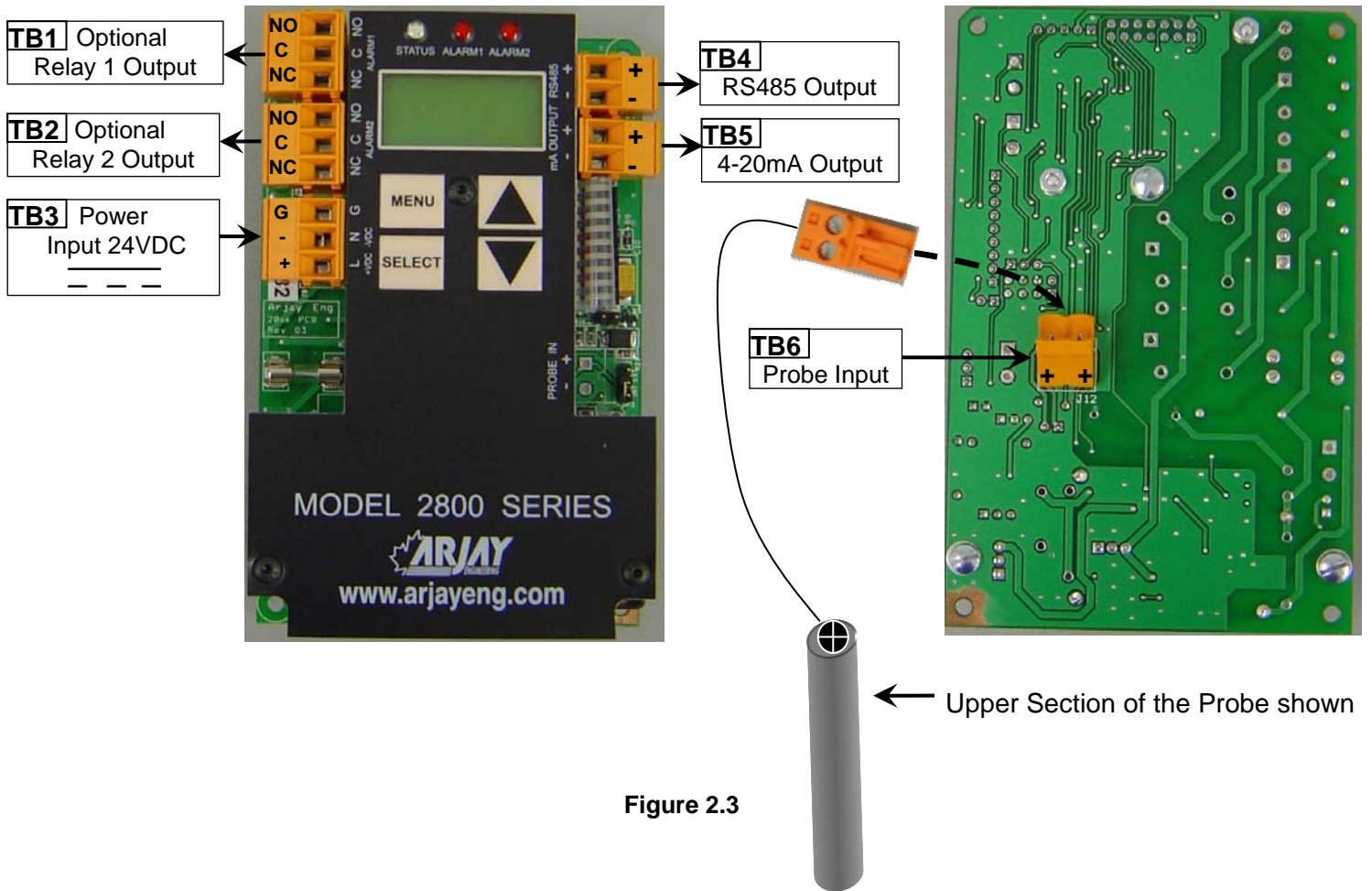

Figure 2.3

TB1/TB2 - Relays Output (Optional for Model 2882 only)

2 SPDT relay, 10 A @ 250 VAC contacts, selectable failsafe or non-failsafe, selectable high or low action, programmable time delay: 0 – 600 seconds

TB3 - Power Input

24VDC power input: connect +VDC and – VDC to TB1. Earth ground is connected to G.

TB4 - Network Output

Connect “RS485 + and –“to the network D+ and D-.







TB5 - 4-20 mA Output (Optional Isolator for Model 2881)

The 4-20 mA is a sourced output referenced to Ground. It is not loop powered.

TB6 - Probe Input

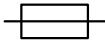
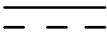
Probe input is wired by the factory. The terminal block is disconnected during shipment for static reasons and has to be re-connected during installation. TB2 has two “+” connections. Either is acceptable.

2.4 Glossary of Symbols

	Attention, consult accompanying documents Attention, veuillez consulter les documents ci-joints.		
	Protective Earth Terre de protection		Fuse Coupe-circuit; fusible
	Direct Current (DC) Courant continu		Normally open relay contacts Contacts travail
	Normally closed relay contacts Contacts Repos		Power off Arrô (mise hors tension)
	Power on Marche (mise sous tension)	L	Live Sous tension
N	Neutral Neutre	G	Ground Terre

3.0 STARTUP AND CALIBRATION

3.1 Startup

Connect the probe terminal block as per Figure 2.3. Power up the 2880 transmitter. The status LED should be green. The LCD should go to the normal operating screen. See section 6.0 Menu Flow Chart.

An instrument setup and field calibration is required on startup. See section 3.3 <2880 Transmitter Calibration> to calibrate the transmitter .

3.2 Menu Flow Chart

3.2.1 Menu Description

The 2880 transmitter has a password protect feature. The default password is 2000. Since the 2880 transmitter has a small LCD, some menu descriptions may be in short form. The following are the menu descriptions:

<i>Diags:</i>	<i>Diagnostics</i>	<i>Alrm:</i>	<i>Alarm</i>
<i>Cal Pts:</i>	<i>Calibration points</i>	<i>Alrm Lvl:</i>	<i>Alarm level</i>
<i>Auto Cal:</i>	<i>Auto calibrate</i>	<i>Diff Hi:</i>	<i>Differential Hi alarm set value</i>
<i>Man Cal:</i>	<i>Manual calibrate</i>	<i>Diff Lo:</i>	<i>Differential Lo alarm set value</i>
<i>Cal Ok:</i>	<i>Calibrate ok</i>	<i>Alrm Del:</i>	<i>Alarm Delay</i>
<i>Cal Err:</i>	<i>Calibrate err</i>	<i>^SP:</i>	<i>Relay Setpoint Hi action</i>
<i>mA out:</i>	<i>mA output</i>	<i>vSP:</i>	<i>Relay Setpoint Low action</i>
<i>mA Span:</i>	<i>mA output span</i>		
<i>Sec:</i>	<i>Seconds</i>		

Menu Flow Chart

The 2880-OWI controller will display a **% Level** value in its normal operating condition.

For calibration purposes, 0% will be considered as 0% water (100% oil) and 100% will be considered as 100% water (0% oil). When determining your % interface values for calibration, consider this in your calculation.

From the main menu, you can select **Cal Only, View, and Change**.

Cal Only allows a two point calibration only. A password is required to enter this menu item and is described in the calibration section. Output parameters and other control features cannot be accessed through this menu. It is recommend to use this menu if only a re-calibration is to be done.

View allows an operator to view the **Calibration** setpoints in pF, the **Alarms** settings (2882 only) such as low or high action, failsafe or non-failsafe and the 0-600 second delay, the **Diagnostics** of raw readings and the **Setup** values such as mA output and ID address. This can be viewed without a password and without risk of changing any values. This information may be requested during technical assistance inquiries.

Change is password protected and allows an operator to enter or change the configuration set-up values indicated in the View.

3.2.2 Data Entry

Data Entry

Press <▲> / <▼> key to increase / decrease the digital value.

Press <SELECT> key to move the cursor.

Press <MENU> key to abort certain screens

3.3 2880 Transmitter Calibration

Power up the 2880 transmitter. The status LED should be green. The LCD should go to the normal operating screen after a series of the following screens (each display for 2 sec.):

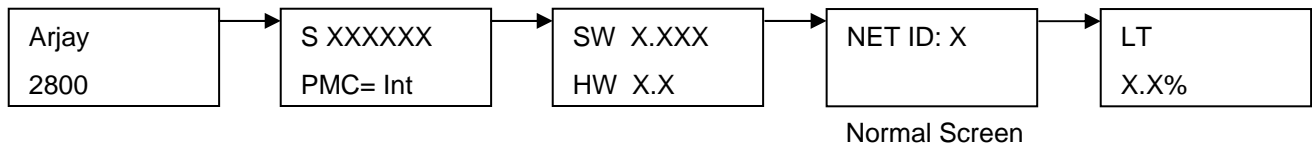

3.3.1 Auto Calibration

As per the Menu Flow Chart in Section 6.0, press Menu key until "Cal only" shows on display. Press select key, enter password "2000" and if auto calibration is required, press <SELECT> key.

1. For the 1st point entry, enter the current interface level value in %. Note: 0% = 0% water and 100% = 100% water. For example an entry of 30% indicates the interface level is at 30% water/70% oil). See section 3.2.3 for value entry description. Confirm the capacitance value in pF is stabilized, press <SELECT> key to accept the 1st point value. The 1st calibration point has been done. The LCD should go to the 2nd point entry menu.
2. Change the interface level in the vessel by a minimum of 10.0%. The interface level may be raised or lowered as long as the interface is along the length of the active probe. A change of less than 10.0% may be used in some applications but is not recommended to ensure calibration accuracy. The capacitance value in pF will increase if raising the interface or decrease if lowering the interface. In some applications where the entrance connection is a flange or extraction fitting, you can simulate an interface change by raising the probe so the interface lowers on the probe. This can only be done if the active portion of the probe is not exposed to air.
3. For the 2nd point entry, enter the new current interface level value in %. For example an entry of 60% indicates the interface level is at 60% water/40% oil) See section 3.2.3 for value entry description. Confirm the capacitance value in pF is stabilized, press <SELECT> key to accept the 2nd point value. The 2nd calibration point has been done.

If the calibration is successful, the display will show "Cal Ok" for a couple of seconds and then return to the calibration menu. If the display shows "Cal Err", then a calibration fault has occurred. Check the following:

1. The 2nd interface % entry value is accidentally left at the 1st calibration point % level.
Re-do the auto calibration according the above steps 1 – 3.
2. The interface in the vessel was not changed from the 1st calibration point.
Re do the auto calibration according the above steps 1 – 3.
3. If 1 or 2 are not the cause, call Arjay Engineering Ltd.: Toll free: (800) 387 – 9487 (North America Only), tel. +1 (905) 829-2418

3.3.2 Manual Calibration

Manual Calibration allows you to override the values that have been set through the automatic calibration. This feature may be used for a number of different reasons. For example.

1. One of the calibration points is desired to be re-calibrated. The user can view the pF reading of the probe in the Diagnostics menu and also record the actual interface level in the vessel at the same time. These values can then be entered in the Manual Calibration to change either Cal Point 1 or Cal Point 2.
2. If a calibration was done using 20% and 60 % as the two values (for example), but it was determined a future date that the 60% should have been entered as 70%.
3. The process level cannot be altered at the time of calibration so a random pF value and % level value is entered as the second point to allow operations until a proper second point can be entered. See method in 1 above.

This completes the calibration procedure for the 2880-OWI Transmitter.

The output functions must now be set up.

4.0 SETUP AND NETWORK

4.1 2880 Transmitter Setup

The 2880 transmitter has the following setup parameters. This is done in CHANGE menu under SETUP. See section 6.0

1. mA Output Span

The mA output span may be set anywhere within the measurement range. Normal mA Span is set at 100% level, but this span value can be changed to a required interface level.

2. mA Output

For Direct mA output, 4 mA = 0% water/100% oil and 20 mA = 100% water/0% oil
For Inverse mA output, 4 mA = 0% oil/100%water and 20 mA = 100% oil/0% water

The unit is shipped as Direct.

3. mA Type

Transmitter can be set for 4-20 mA or 0-20 mA.

The unit is shipped as 4-20 mA

4. Defaults

Factory settings are pre-configured into the unit based on the most typical set-up required for this application. This provides for a quick and easy calibration at site but can be changed for special applications. If the setup has been changed, this will change back to the factory defaults.

5. NET ID

The ID number is used only for network applications. To communicate on a network, each controller must have a unique ID number.

Important: if multiple units on a network have the same address, network errors will result.

6. Filter

Data filtering is used to smooth data from a sudden change and minimize fluctuating readings. For example, a 5 second setting means the calculated value of the capacitance and resulting values of pF will start to respond immediately but will take 5 seconds to reach their final values. The factory default is 0 to provide an immediate and active response.

4.2 2882 Transmitter Relay Setup (2882 Option only)

2882 Transmitter has 2 relays (A1 and A2) that allow 4 parameters per relay plus a time delay value, which is common to all relays:

1. **HIGH ALARM (Diff Hi) POINT.** This value is specified in % level. Above this value, relay action is taken depending on the Relay Action and Failsafe settings. Factory default is 40% for A1 and 80% for A2.
2. **LOW ALARM (Diff Lo) POINT.** This value should be less than the High control point. Below this value, relay action is taken depending on the Relay Action and Failsafe settings. Factory Default is 20% for A1 and 60% for A2.
3. **RELAY DELAY.** Minimum time in seconds for an alarm to exist before the corresponding relay changes to its alarm state. The relay alarm state depends on the Relay Action and Failsafe settings. Factory default is 0.
4. **RELAY ACTION.** High or Low Action. For high action, the alarm is set when the % level rises above the high alarm set point and is reset when the % level drops below the low alarm set point. For low action, the alarm is set when the % level drops below the low alarm set point and is reset when % level rises above the high alarm set point. Factory default is HIGH action.
5. **FAILSAFE.** Failsafe typically means that the relay is normally (when not in an alarm condition) held in an energized state. In an alarm condition, the relay is de-energized i.e. identical to when the instrument power is shut off. The rationale is that the alarm condition should match the Power Fail condition. Factory default is Yes.

The following table shows the effect of the Relay Action and Failsafe settings.

Relay Action	Failsafe Setting	Effect
High	No	Alarm condition when process level rises above the High Setpoint for at least the alarm delay period. Alarm condition remains active until the process level drops below the Low Setpoint. No action is taken when the process level is between the High and Low Setpoints. In the alarm condition, the corresponding alarm LED is turned ON, and the relay is energized.
High	Yes	Alarm condition set and reset as above. In the alarm condition, the corresponding alarm LED is turned ON, but the relay is de-energized.
Low	No	Alarm condition when process level drops below the Low Setpoint for at least the alarm delay period. Alarm condition remains active until the process level rises above the High Setpoint. No action is taken when the process level is between the High and Low Setpoints. In the alarm condition, the corresponding alarm LED is turned ON, and the relay is energized.
Low	Yes	Alarm condition set and reset as above. In the alarm condition, the corresponding alarm LED is turned ON, but the relay is de-energized.

4.3 2880 Transmitter Network

The 2880 Transmitter may be monitored and calibrated via RS-485 protocol compatible digital communications.

Typical features are:

1. Ease of wiring in multiple level point monitoring:

Up to 255 Model 2880's (or other Arjay 2800 Series level monitors) may be connected together in a daisy chain (2 wire communication plus power wiring) connection to an Arjay Remote Access monitor or customer control system which allows viewing data and setup of any of the transmitters on the network. The 4-20mA output may still be used if necessary.

2. Setup for the 2880 for network operation:

Each 2880 transmitter must have a unique number to connect in a network system. See section 6.0 Menu Flow Chart, CHANGE menu for details to change the ID number.

4.3.1 Modbus Configuration

Parameter settings: 9600 Baud Rate; Even Parity, 8 Data Bits and 1 Stop Bit.

Wiring connection: RS485 (+) connect to D+; RS485 (-) connect to D-.

4.3.2 2800 Series Modbus Register Mapping

REG	Zero Based	DESCRIPTION	TYPE	No. of Reg
40001	0	Serial Number	float	2
40003	2	Hardware Rev / Software Rev	byte	1
40004	3	Sensitivity / Mode	byte	1
40005	4	Instrument Status	int	1
40006	5	Model / Modbus Address	byte	1
40007	6	Relay2 Setup / Relay 1 Setup	byte	1
40008	7	Password	int	1
40009	8	XA "A" cal parameter	float	2
40011	10	XK "K" cal parameter	float	2
40013	12	XC "C" cal parameter	float	2
40015	14	Filter	float	2
40017	16	Slope – pF per % level	float	2
40019	18	Offset – pF for empty vessel	float	2
40021	20	mA output span value	float	2
40023	22	mA output Zero value	float	2
40025	24	mA output Trim Slope value	float	2
40027	26	mA output Trim Offset vlaue	float	2
40029	28	Cal1 PV: 1st calibration point level value in %	float	2
40031	30	Cal2 PV: 2nd calibration point level value in %	float	2
40033	32	Cal1 pF: 1st calibration point capacitance value in pF	float	2
40035	34	Cal2 pF: 2nd calibration point capacitance value in pF	float	2
40037	36	Relay 1 : Differential High Alarm [% Level]. Only used for Linear Level type. Not used for Single Point Alarm application	float	2
40039	38	Relay 2: Differential High Alarm [% Level]. Only used for Linear Level type. Not used for Single Point Alarm application	float	2
40041	40	Relay 1: Differential Low Alarm [% Level] OR Single Point Alarm [pF]. Single Point Cal: used as captured pF during cal	float	2
40043	42	Relay 2: Differential Low Alarm [%Level]. Only used for Linear Level type. Not used for Single Point Alarm application	float	2
40045	44	Relay 1 On delay [in seconds]. Only used for Linear Level or Single Point Alarm application	int	1
40046	45	Relay 2 On delay [in seconds]. Only used for Linear Level type. Not used for Single Point Alarm application	int	1
40047	46	mA Analog Output	float	2
40049	48	Oscillation Frequency	float	2
40051	50	Frequency	float	2
40053	52	Capacitance	float	2
40055	54	Filtered Capacitance	float	2
40057	56	Level	float	2

5.0 TROUBLESHOOTING

CONDITION	DO THIS
1. Status LED is OFF and the LCD display is off	Check the power to the unit. If the unit is a 24/12VDC model, check the external source is 24V/12VDC. Make sure the polarity is correct. If the unit is a 100-240VAC model, then check the Line, Neutral and Ground wiring is correct.
2. If the status LED is RED	<p>This indicates a major error such as memory failure, no probe signal etc. Check the following:</p> <ul style="list-style-type: none"> • Make sure the probe wiring is correct and plugged into controller. • Microprocessor may have lost its parameters due to a surge in the line. Go to Diagnostic Menu (see 6.0 Menu Flow Chart) to check the Calibration values, frequency and capacitance values • Call Arjay Technical Support.
3. mA output does not match the level.	<p>First determine if the problem is in the mA output or if the unit is not calibrated to the vessel.</p> <ul style="list-style-type: none"> • Check the calibration values, go to View Menu (see Section 6.0 Flow chart) and read the 2 calibration points values. If the calibration values are not correct, redo calibration (see section 3.3 2880 Transmitter Calibration) If the calibration values are correct, go to next step to check mA output. • Check the mA output Action (direct or inverse) and mA output Span are set as desired. See section 6.0 Flow chart / Change menu. • If the mA output still does not match the level, then call Arjay Technical Support. <p>IMPORTANT: THE UNIT <u>SOURCES</u> mA OUT FROM THE mA OUTPUT TERMINAL. <u>THIS TERMINAL SHOULD NOT BE CONNECTED TO +24V</u>. IT IS NOT A 2 WIRE mA TRANSMITTER. See Figure 2.1 for electrical hookup details</p>

ARJAY ENGINEERING TECHNICAL SUPPORT

(800) 387-9487

+1 (905) 829-2418

www.arjayeng.com

6.0 FLOW CHARTS

NORMAL OPERATING DISPLAY

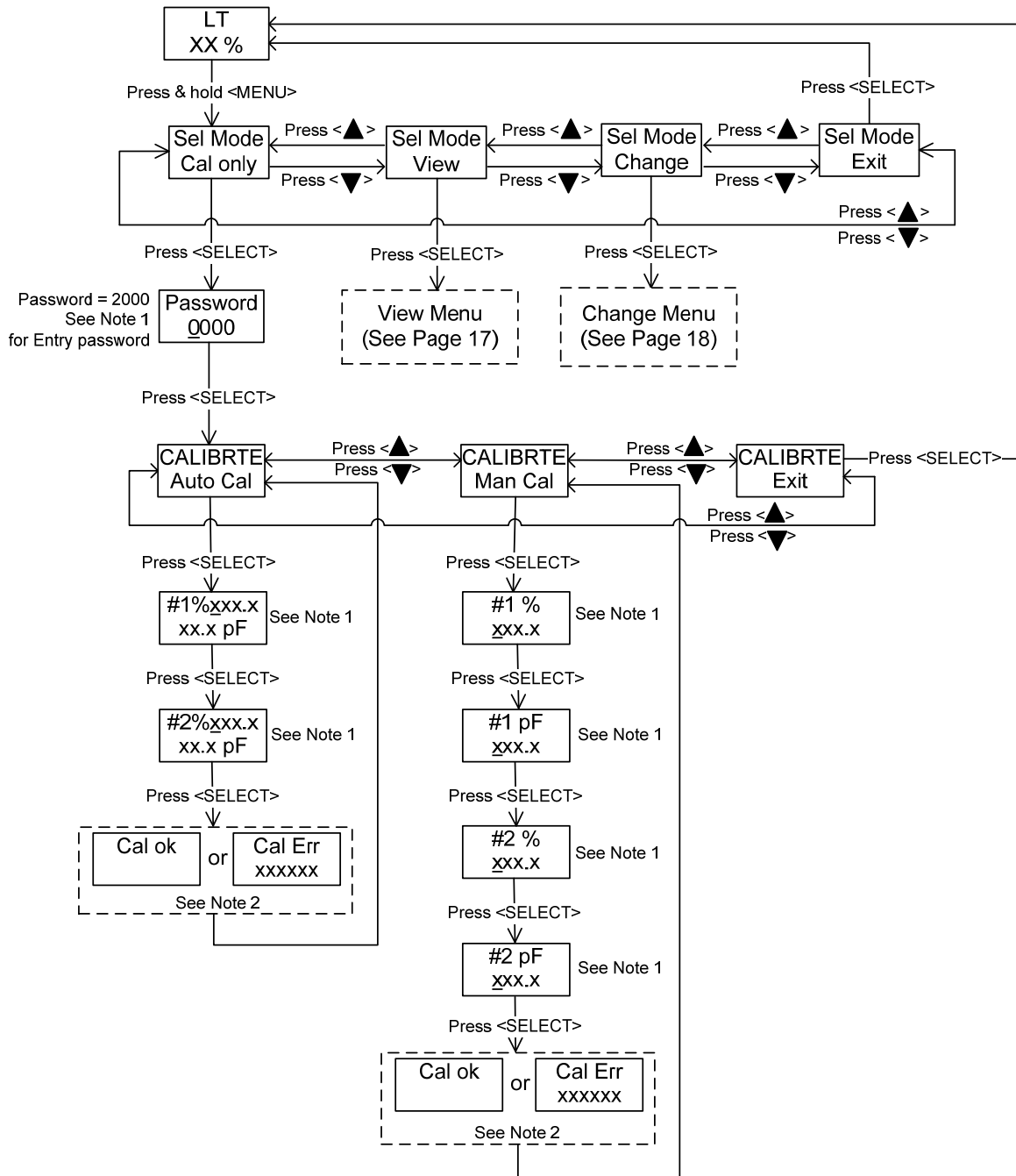

Note 1: Data Entry

 : Flash cursor indicates to entry the value

Press <▲>/<▼> key to increase / decrease the digital value.

Press <SELECT> key to move the cursor.

Note 2: Calibration information, it only shows about 2 seconds

VIEW MENU

