

Water Cut Monitor with In-Line type Probe Model WCM 7300

The **Water Cut Monitor with In-Line type Probe** is designed to provide the highest possible sensitivity, resolution, and accuracy for water content determination in crude oil, other hydrocarbons, or other low dielectric liquids from a maximum of 25% to levels below 1000 parts per million (ppm). In oil and natural gas (condensate) production, water cut and S&W measurements are significantly improved with the Water Cut Monitor with In-Line type Probe technology. Enhanced digital signal processing and full product temperature compensation are two of the technological advancements utilized by this device. Water cut, process temperature or probe electrical value can be selected for viewing without removing the conduit cover by use of a supplied magnet to operate an internal reed switch.

A collaboration with FMC Technologies has made this unit available to compliment the full line of Arjay Engineering Ltd. Oil/Water products.

Product Temperature Compensation

The base dielectric constant (Dk) of oils can change with changes in temperature. This can cause traditional monitors to change output without a variance in water content. For example; for a 10°F change, a typical crude oil may show a reading shift of as much as 0.1%, which normally would be considered as water. The Water Cut Monitor with In-Line type Probe measures product temperature and calculates a corrected cut reading, providing a true water or S&W cut at any temperature up to 160°F.



Applications

LACT (Lease Automatic Custody Transfer) Units

Detect and provide relay contact closure that can be used to reroute oil that has excess S&W.

Pipeline Loading

Monitor transfer of petroleum/condensate products from loading facilities.

Dehydration Equipment

Determine and enhance equipment efficiencies, by monitoring the product and indicating water content.

Fuel Oil Monitoring

Determine contamination of fuel oil by condensation, or other external factors, before entry to engines.

Storage and Treating Facilities

Monitoring and early detection of undesirable conditions as well as interface detection during de-watering of storage tanks.

Features

NACE Adaptable

Can be modified for use in sour service.

Specifications

Power Supply

20 – 30 VDC +/- 10% @ nominal, 100 mA max.

Measurement Full Scale Range

0 – 25%. Field Adjustable 0 – 5%, 0 – 10%, 0 – 25%
 Minimum detectable level: 1,000 ppm (0.1%)

Sensitivity / Resolution

0.01% - 100 ppm

Accuracy

Accuracy is defined as the normal variance observed in the field between the Water Cut Monitor with In-Line type Probe reading and the water grindout of the oil. These observed variance numbers are larger than the stated sensitivity/resolution of the WCM because the Dk of the oil in actual field operations is not constant but is continuously changing due to varying amounts of trace contaminants such as chemicals, minerals, solution gas, etc. These cause small changes in the Dk which is independent of the water cut. The WCM "sees" these changes and so indicates them. In the laboratory the WCM easily detects and indicates changes of 100 ppm, or less. This accuracy is seldom observed in the field because of the reasons stated above. The accuracy statements shown are what is normally obtainable (based on multiple installations) in the field and not on controlled testing in a lab.

Normal variances are:

- +/- 0.05 from 0 to 5% water
- +/- 0.10 from 5 to 10% water
- +/- 0.15 from 10% to 15% water
- +/- 0.20 to 0.25 from 15 to 25% water

Probe Dimensions

Refer to table below the WCM with In-Line probe drawing

Display

One line 16 character, alphanumeric LCD showing by selection: Water Cut / Process Temperature / Probe Electrical Value
 Red/Green LED showing good oil, bad oil, or by passing, condition

Pressure Ratings

As per Flange selection, 1440 psig max. (others by special order)
 NPT - 1440 psig max.
 Victualic grooved - 350 psig

Outputs

Analog 4 - 20 mA, Isolated, Loop powered
 Alarm Relay 1 X SPDT, 10 A @ 24 VDC

Enclosure

NEMA 7

Approvals

CSA Class I Division 1 Groups C & D
 ABSA CRN No. 0F07240.2

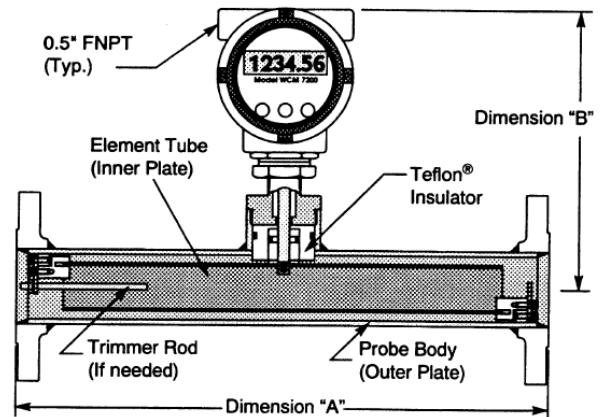

Size	Dimension "A"	Dimension "B"	Approx. Weight (lbs)
2 inch	17.0" (431)	8.6" (218)	20
3 inch	32.0" (811)	9.0" (228)	45
4 inch	32.0" (811)	9.5" (241)	72
6 inch	32.0" (811)	10.5" (266)	127
8 inch	32.0" (811)	11.5" (291)	190
10 inch	32.0" (811)	12.6" (319)	268
12 inch +	Consult Factory		

Note: Dimensions - Inches to the nearest tenth (millimeters to the nearest whole mm), each independently dimensioned from respective engineering drawings.

Order Reference:

P/N **A00699**

Water Cut Monitor with In-Line type Probe

Model **WCM 7300**